

NAKASHIMADA Material: Tool Steel Carbide Inserted. To order, specify Tool Number and "A" Dimension.

TOOL NO.	MACHINE TYPE	T	W	L	S	Ø
800	1/8" H10-10A	5 mm	16 mm	55 mm	12.24 mm	30°
900	5/32" PF-420	6 mm	20 mm	65 mm	15.08 mm	30°
900	3/16" H15/15A	6 mm	20 mm	65 mm	15.08 mm	30°
1000	1/4" H20/20A/20AU/20U/PF630	7 mm	28 mm	70 mm	21.92 mm	30°
1500	1/4" H20C/20E/20F/CS	12 mm	28 mm	70 mm	21.26 mm	20°
1600	1/4" DH20	10 mm	25 mm	75 mm		
1700	1/4" H25	30 mm	30 mm	87 mm		
1300	5/16" PF860	8.5 mm	35 mm	90 mm	27.33 mm	30°
1200	3/8" H30/30A	20 mm	35 mm	120 mm	30.94 mm	45°
1400	1/2" PF1280	19.8 mm	45 mm	130 mm	38.70 mm	45°

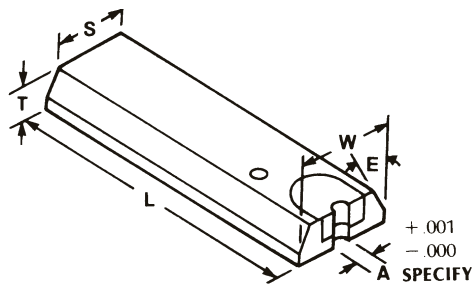

CARLO SALVI Material: Tool Steel Carbide Inserted. To order, specify Tool Number and "A" Dimension.
 Note! Standard Knives Furnished with Square Nose. For Short Blanks specify "D" Dimension.

TOOL NO.	MACHINE TYPE	T	W	L	H
7000	1/8" PSV-RF/SV	8 mm	12 mm	45 mm	M 5
7050	5/32" TP2/CL-RF/PL	8 mm	12 mm	65 mm	M 6
7100	3/16" 476/SV-RF/476/SV	10 mm	12 mm	65 mm	M 6
7200	1/4" 635/SV-RF 635/SV	12 mm	20 mm	90 mm	M 8
7250	1/4" INT/CL-RF/ML	11 mm	20 mm	90 mm	M 8
7300	5/16" RF/873/SV	13 mm	25 mm	115 mm	M 12
7350	5/16" TM/CL-RF/GL	—	—	—	—

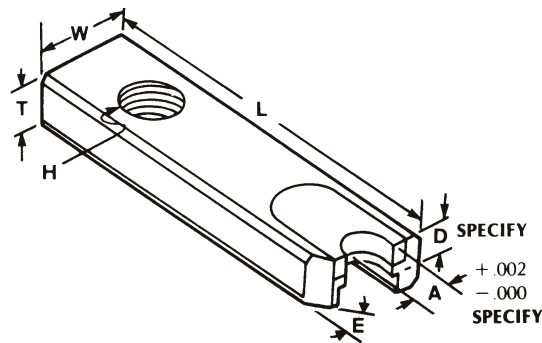

PRICES FURNISHED UPON REQUEST

SACMA

Material: Tool Steel Carbide Inserted. To order, specify Tool Number and "A" Dimension.

TOOL NO.	MACHINE TYPE	T	W	L	H
3000	SP-01	.390	.704	2.165	5/16-18
3100	SP-11	.452	.941	3.051	3/8-16
3200	SP-21	.547	1.098	3.543	9/16-12
3300	SP-31	.666	1.700	4.882	9/16-12

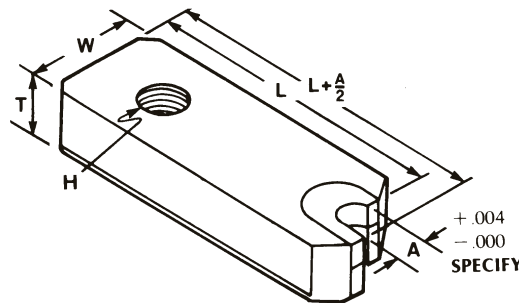
WATERBURY FARREL

 Material: Tool Steel Carbide Inserted. To order, specify Tool Number and "A" Dimension.
 Note! Standard Knives furnished with Square Nose. For Short Blanks specify "D" Dimension.
 "E" Dimension as shown or specify your needs.

TOOL NO.	MACHINE TYPE	T	W	L	H	E
4000	1/8" HEADMASTER	3/8	3/4	2-1/16	1/4-28	20°
4150	No. 0 TOGGLE	.341	11/16	2-1/4	5/16-18	20°
4150	No. 0 TUB RIVET	.341	11/16	2-1/4	5/16-18	20°
4150	3/16 HIPRO	.341	11/16	2-1/4	5/16-18	20°
4200	#10 HIPRO LONG WORK	.341	11/16	2-1/4	5/16-18	20°
4250	#10 HIPRO SHORT WORK	.341	11/16	2-1/4	5/16-18	20°
4300	No. 1 TOGGLE	.371	1-1/16	2-9/16	7/16-20	20°
4300	No. 1 TUB RIVET	.371	1-1/16	2-9/16	7/16-20	20°
4400	3/16 HEADMASTER	3/8	1-1/16	2-9/16	5/16-24	20°
4450	No. 2 TOGGLE	.371	1-3/8	3-1/16	7/16-20	20°
4500	5/16 HIPRO	1/2	1-7/16	3-11/16	5/8-11	20°
4550	No. 3 TOGGLE	1/2	1-11/16	4-13/16	5/8-11	20°

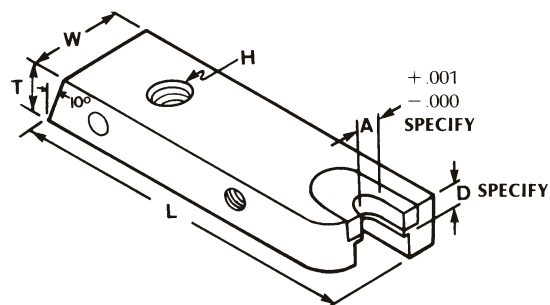

PRICES FURNISHED UPON REQUEST

HARTFORD

Material: Tool Steel Carbide Inserted. To order, specify Tool Number and "A" Dimension.

TOOL NO.	MACHINE TYPE	T	W	L	H
5000	1/8" HARTFORD #2-425	.392	.875	3.080	5/16-24
5100	1/8" HARTFORD #2-450	.392	.940	2.800	5/16-24
5200	3/16" HARTFORD #3-300 #3-350	.392	1.100	3.270	3/8-16
5300	5/16" HARTFORD #4-250 #5-250	.471	1.344	3.780	3/8-24

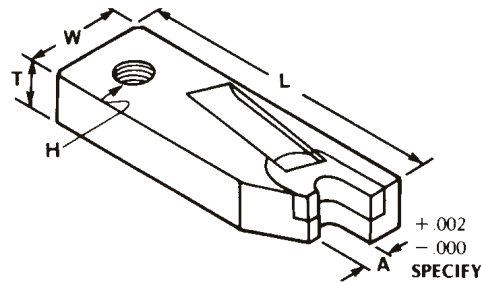
LEWIS

Material: Tool Steel Carbide Inserted. To order, specify Tool Number and "A" Dimension.

TOOL NO.	MACHINE TYPE	T	W	L
8000	OSC	1/2	11/16	2-1/2
8040	1C	9/16	7/8	2-1/4
8100	2C	3/4	1	2-7/8
8180	2CV	3/4	1	2-7/8
8200	2C SC	3/4	1.137	3
8320	7C1-254	9/16	3/4	2-3/4
8340	8C-9C	7/8	55/64	3-3/4
8380	9F	7/8	1-5/8	3-3/8
8400	10C	1-1/8	2.300	4-1/2
8440	3F	1/2	1	2-1/4
8480	4F	3/4	1-1/4	2-1/2

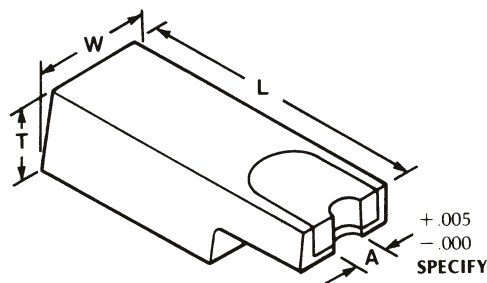
PRICES FURNISHED UPON REQUEST

NATIONAL

Material: Tool Steel Carbide Inserted. To order, specify Tool Number and "A" Dimension.

TOOL NO.	MACHINE TYPE	T	W	L	H
2000	1/8" DSSD	.250	3/4	1-13/16	3/8-16
2100	3/16" DSSD	.312	1-1/16	2-5/16	7/16-14
2200	1/4" DSSD	.375	1-3/8	3-1/2	1/2-13
2300	5/16" DSSD	.500	1-7/16	4	5/8-11
2400	3/8" DSSD	.437	1-1/2	4-1/4	5/8-11
2500	1/2" DSSD	.562	1-7/8	5	3/4-10

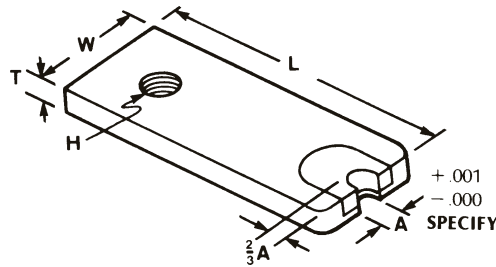

WATERBURY

Material: Tool Steel Carbide Inserted. To order, specify Tool Number and "A" Dimension.

TOOL NO.	MACHINE TYPE	T	W _C	W _R	L _C	L _R	H
6000	3/16" WTBY	5/8	13/16	—	1-11/16	—	5/16-24
6100	3/16" WTBY	5/8	—	7/8	—	1-3/16	5/16-24
6200	1/4" WTBY	3/4	1-1/16	—	2	—	3/8-24
6300	1/4" WTBY	3/4	—	1-1/8	—	1-7/16	3/8-24
6400	5/16" WTBY	7/8	1-3/16	—	2-3/8	—	7/16-20
6500	5/16" WTBY	7/8	—	1-1/4	—	1-11/16	7/16-20
6600	3/8" WTBY	1	1-5/16	—	2-11/16	—	1/2-20
6700	3/8" WTBY	1	—	1-3/8	—	1-15/16	1/2-20
6800	1/2" WTBY	1-1/4	1-9/16	—	3-1/2	—	5/8-18
6900	1/2" WTBY	1-1/4	—	1-1/2	—	3-1/4	5/8-18

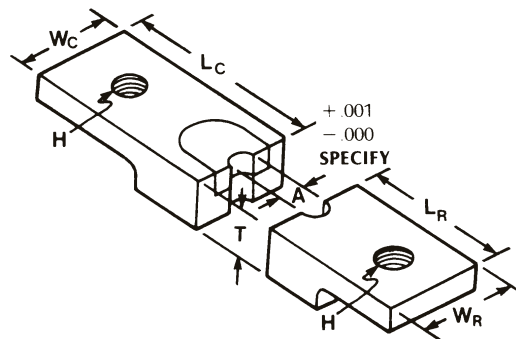

PRICES FURNISHED UPON REQUEST

**COLD HEADER
MACHINE CORP.**

Material: Tool Steel Carbide Inserted. To order, specify Tool Number and "A" Dimension.

TOOL NO.	MACHINE MAKE	HEADER NO.	T	W	L	H
9000	TSUKIBOSHI	MS 200	1/4	7/8	1-15/16	1/4-20
9050		MT 200	1/4	7/8	1-15/16	1/4-20
9100		MT 300	.300	.995	2-3/16	3/8-16
9150		MT 350	.300	.995	2-3/16	3/8-16
9200	TOKYO JOODKI	HO Header Copper Cutter	9.5	25	57	M 8
9200		HO Header Silver Cutter	9	25	60	M 8
9300	AYASE SEIKI	MS 340	.275	5/8	2.480	5/16-18
9400		MTR 360	.315	.786	2-5/8	5/16-18
9500		MS 360	.275	.632	2-1/8	5/16-18
9600	KOSONO	MS 350	.300	.995	2-1/8	3/8-16
9650		MS 400	.375	1-1/4	2-1/2	
9700	SUKEGAWA	MS 500	.400	1-1/4	2-15/16	
9730		MS 500L	7/16	1-1/4	2.910	

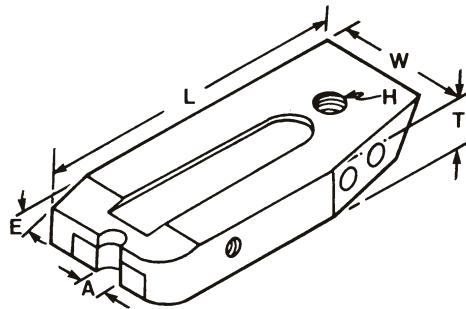

+ .002
- .000
SPECIFY

PRICES FURNISHED UPON REQUEST